

Table of Contents	
1. Important safety instructions	Page 2
2. Product description	Page3
3. By-pass diodes	Page 4
4. Operating voltage	Page 5
5. Mechanical assembly instructions	Pages 7 - 12
6. Locating the protection fuses	Page 13
7. Recommendations for use	Page14
8. Warnings and electrical hazards	Pages15 - 16
9. Module maintenance	Page 17
10. Current-voltage curves	Page 18
11. Module frame grounding	Page 19
12. Declaration of CE conformity	Page 20

Safety Instructions



This instruction manual and the product labels contain a series of important safety messages. They should be read carefully before handling or connecting the photovoltaic module since the module produces electricity as soon as the cells are exposed to sunlight.



The safety warning symbol is shown before each safety message included in this instructions manual. This symbol indicates that there is a personal safety hazard which would affect both you and others and cause damage to the products or other property.



Warning: any fault in the module caused by failure to comply with the warnings stipulated in this instructions manual will lead to the complete withdrawal of the module's guarantee, together with the full exoneration of PV POWER TECH from any responsibility derived of any kind.

Product Description

Your photovoltaic Standard module is comprised of the following elements:

1. PV Junction Box: IP65 compliant junction box with 3 OR 6 high quality diodes. Connectors are equipped with mechanical locks to ensure a safe and a secure connection.

2. Backsheet: Improves weather resistance and increases light reflection.

3. EVA (Ethylene Vinyl Acetate): Creates a tight seal and renders the cells its long life.

4. Cells: Premium grade high efficiency polycrystalline next generation cells.

5. Glass: 3.20mm Low Iron Toughened, High Transitivity, Tempered High Impact resistance glass - Textured on the inside to increase reflection and efficiency.

6. Aluminum Frames: Robust, Anodized Non-corroding aluminum snap-fit frames with pre-drilled drainage and grounding holes.

By Pass Diodes

The photovoltaic module must be protected with by-pass diodes. The absence of these diodes could cause the photovoltaic module to malfunction or even ultimately lead to its destruction as it could catch fire. PV Power Tech delivers its modules with by-pass diodes included inside the Junction box.

The photovoltaic cells have two operating modes: it operates as a current generator or as a current consumer. A cell exposed to solar radiation provides a current ranging between 6 and 8 amps with a potential difference of around 0.6 volts. However when a cell is partially shaded by the leaves of a tree for example it starts to consume the electricity generated by the other cells to which it is connected. At the area of the cell that changes from a sunlit area to a shaded area an effect known as a "hot-spot" occurs whereby due to the circulation of current the overheating produced is such that it may set the materials on fire and destroy the module. The maximum number of cells connected in series per diode is 20 cells for all our modules.



For the above mentioned reasons it is extremely important that the by – pass diodes are not removed from the Junction Box.

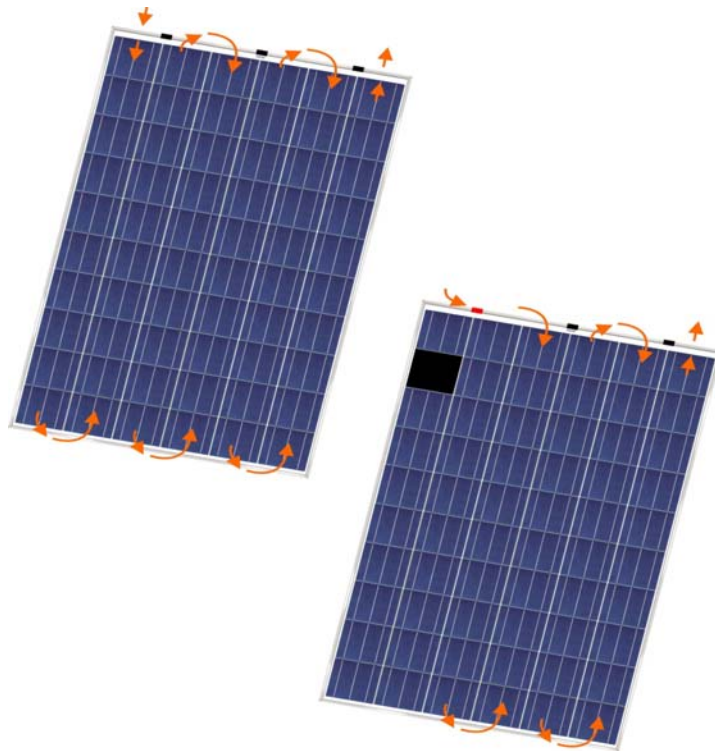

Operating Voltage:

In the event of by-pass diode failure they must be replaced with original by-pass diode spares and by trained and certified personnel authorized by PV Power Tech. From the moment that the failure in the diodes occurs and until they are replaced the affected photovoltaic module(s) must remain disconnected from the other modules on the photovoltaic array thus guaranteeing that the circuit remains open. In any event the decision to change the diodes is the responsibility of PV Power Tech.



WARNING: Failure to use original spares or parts replaced by personnel without the authorization of PV POWER TECH, etc., shall lead to the withdrawal of the guarantee of the photovoltaic module and PV POWER TECH shall automatically be exonerated from any responsibility for damage caused to property or harm caused to people.

$$\text{Max. no. of Modules} = \frac{\text{Maximum System Voltage}}{\text{Voc } 25^{\circ}\text{C} + ((T^{\text{a}} - 77) \times \text{no cell} \times (-0.00215))}$$

Mechanical Assembly of the modules:

When assembling the modules the safety conditions stipulated in the Low Voltage Directive 93/68/EEC and 2006/95/EEC and the Framework Directive on Safety and Health at Work 89/391J/EEC, 91/383/EEC, 2003/134/EEC, 89/654/EEC, 89/655/EEC, 89/656/EEC, 92/57/EEC and 92/58/EEC.

Standard Modules must be anchored in a secure manner using special fixing systems or assembly sets for photovoltaic systems. When Glass laminates have to be installed in buildings special profile for structural glass has to be used silken modules have to be fixed by the four edges or by the two long edges.

Install the module so that the connection box cable holders are never oriented upwards in the direction of the inclination.

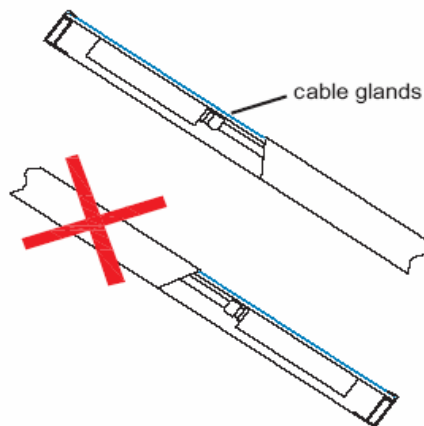

The modules should be mounted using a structure which must have been designed by a qualified technician to support the loads produced by wind and snow as indicated in the Directive of Construction (89/106/EEC) and the Directive 2002/91/EEC Energy Efficiency Building.

The ideal orientation for the photovoltaic module is towards geographic south in the northern hemisphere or towards geographical north in the southern hemisphere. The inclination of the module will depend on the requirements of the installation itself (grid connection systems or isolated supply). The module must be mechanically fixed at least at these four points. The module inclinations should be a minimum of 12°.

Leave a minimum space of 15 mm (0.6 inches) between the modules to avoid contact due to thermal expansion.

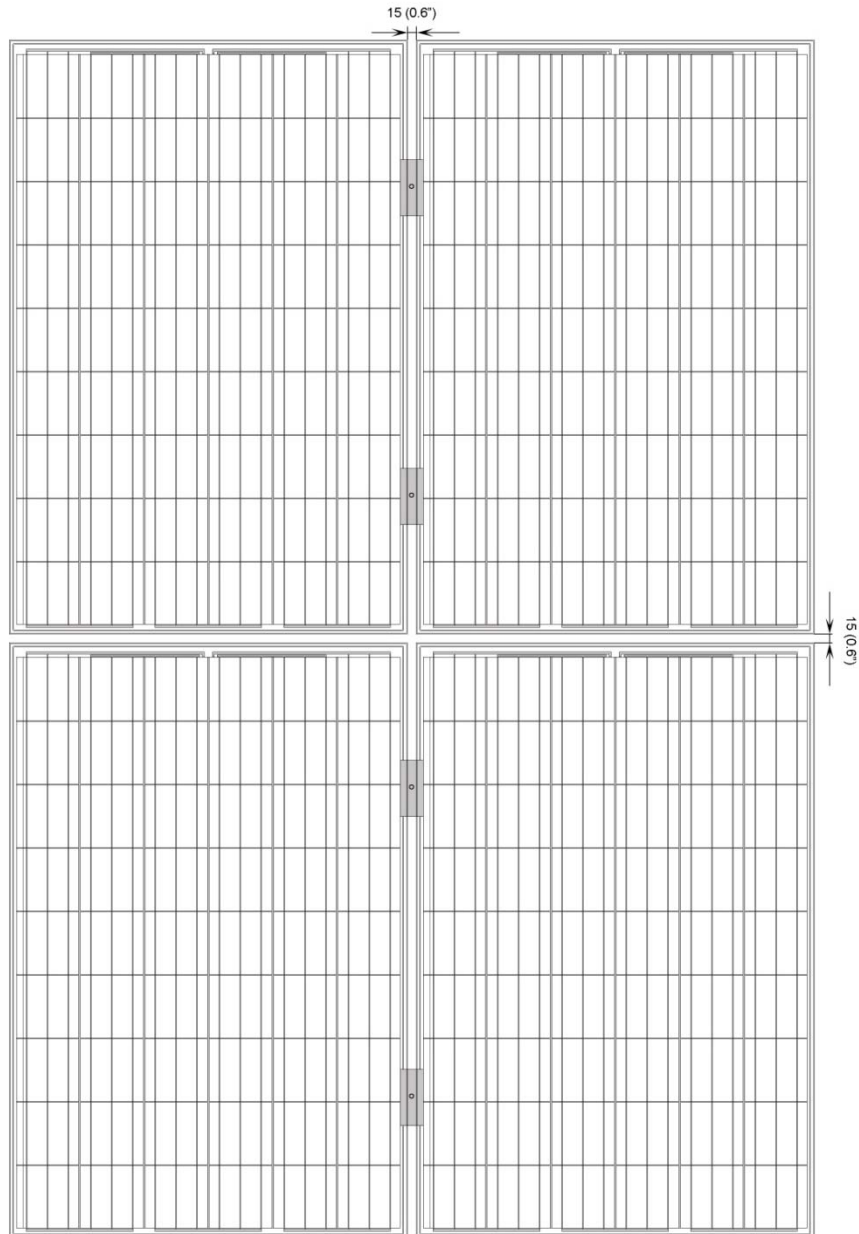

Other racking systems that differ from the prescribed ones can be used as well (under the responsibility of the installer) such as clamps or clips provided that no holes are made in the frame. These systems must also comply with the permitted wind and snow loads.

PV Power Tech is not responsible for any damage to PV modules caused by the use of inadequate fixing systems which for example create momentary loads or frame deformations with irregular supporting surface asymmetric fixings or any other improper way of installing.

PV modules are not structural elements. Do not consider them as part of the structure.

Do not install the modules with reduced inclination angles this could cause dirt accumulation on the glass and the frame edges.

In the case of roof-top PV modules leave space at their back side to allow for proper ventilation (minimum of 50 mm [2 inches]).

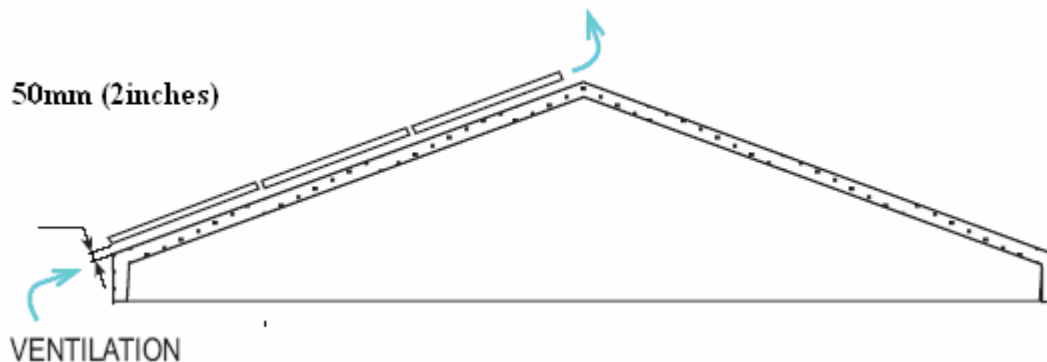

Make sure that the roof construction is appropriate for PV installations that the roof complies with the fire resistance regulations for PV systems (if not it must be adjusted first), and that if any perforation needs to be performed the roof is perfectly sealed and water cannot filter into the building.

Always shield the modules back surface from contacting outside objects or structure parts especially when the module is under load. The back coating could be damaged.

Maximum permitted loads for PV modules refer to uniformly distributed loads of wind and/or snow. Therefore do not install PV modules in areas in which snow tends to accumulate or icicles and/or ice plugs could obstruct water drainage and cause damage to the module.

In general handle modules with extreme care before they get to the place of installation. A blow on the side can break the entire glass structure that protects the module's active front.

Make sure that the module is not loaded with anything that could cause the hardened glass to break.

If the module is supplied without the aluminum frames handle it as follows:

Avoid direct contact of glass and metal between the module and the structure parts.

Leave enough space for expansion and contraction of the different materials due to temperature changes. Use rubber joints between the lamination and fixings.

When fixing the laminate to the support structure use fixing clamps. Listed below are details of where to position the fixing clamps on each model of PV Power Tech PV module.

PVQ3 (Black) and ECO (Black) 220 – 240 watts modules:

Any PV Powertech modules of the dimensions 1639mm x 989mm. must use 4 x 70mm fixing clamps which should be placed on each lengthwise edge (1639mm) of the modules as shown in the diagram below:

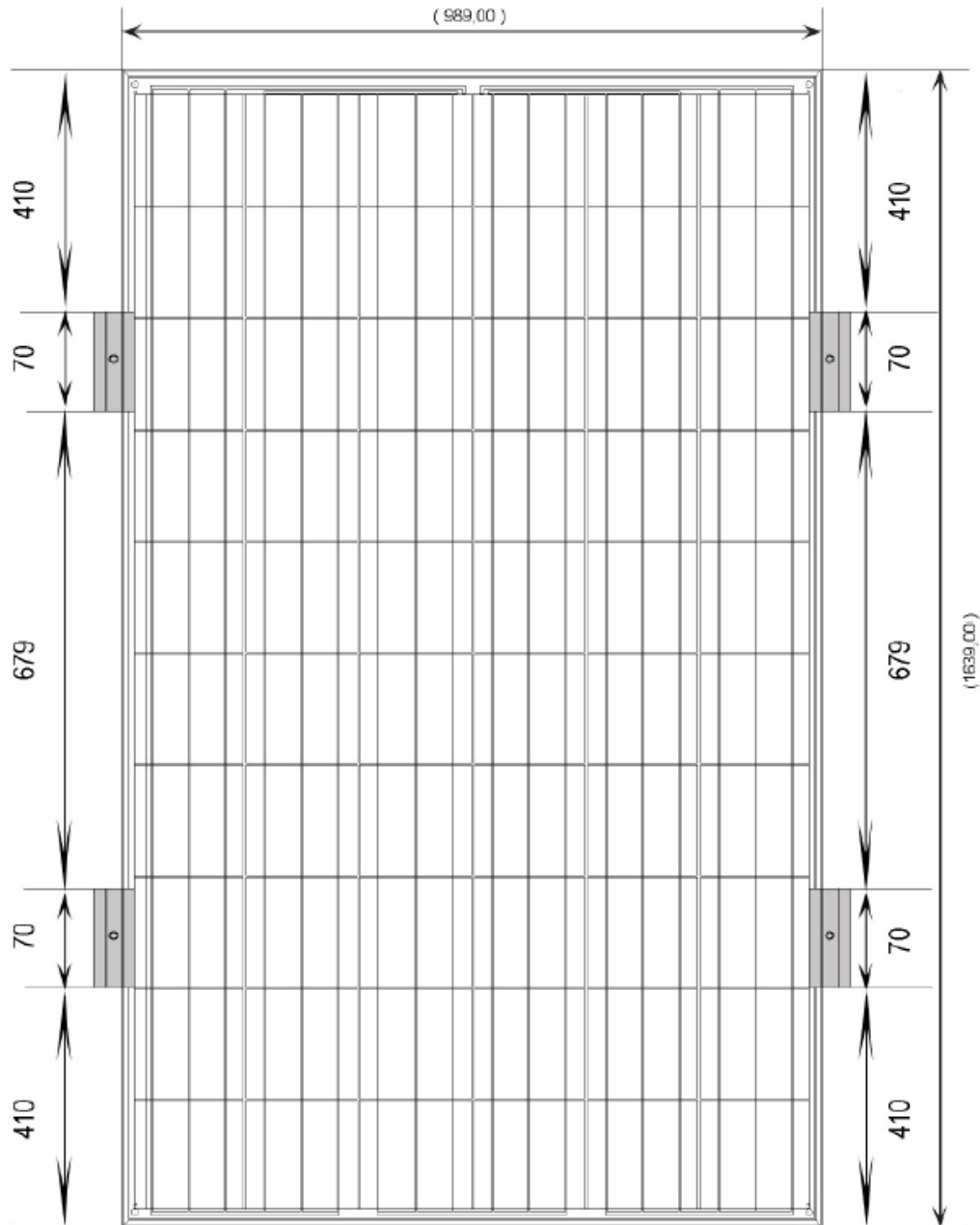

Locating the protection fuses

Attention: Under normal conditions, a photovoltaic module is likely to experience conditions that produce more current and/or voltage than reported at standard test conditions. Accordingly, the values of ISC and VOC marked on this module should be multiplied by a factor of 1.25 when determining component voltage ratings, conductor ampacities, fuse sizes, and size of controls connected to the PV output.

For field connections use minimum No. 4 AWG copper wires insulated for a minimum of 90 °C.

Once the modules are connected in series to obtain the correct input voltage for each type of inverter it is essential that protection fuses are located between the inverter and each series. These fuses will facilitate maintenance and control tasks but they will mainly protect the series from each other should the polarity of one of the series of modules be incorrectly connected.

Series fuse (overcurrent protection) rating of 15 A.

The design level current for these fuses must be multiplied by a factor of 1.25 times the I_{sc} of the photovoltaic module measured under standard test. The fuses must be suitable for direct current systems with a breaking capacity greater than the sum of the intensities of the series of connected modules

Failure to install this type of protection in the event of an incorrect positive and negative polarity connection will cause the reversed series to act as an electricity receiver causing severe damage to both the diodes and the other electrical components of the modules.



WARNING: Failure to comply with the provisions of this section will lead to the loss of guarantee and the exoneration of PV Power Tech from any type of responsibility for damage to property or injury to people.

Recommendations for use:

- Ensure that the module is located appropriately: it must not be placed beneath the shade of streetlights, trees other buildings or even shade produced by other modules. Electricity production can be considerably reduced by the effect of shade.
- Install the PV module allowing air to circulate freely (see also section 6 of this manual). This will facilitate the natural ventilation of the module. The module is designed to work in temperatures between -40°C and $+85^{\circ}\text{C}$. In addition both polycrystalline and monocrystalline modules produce more energy in lower temperatures. Therefore proper ventilation favors higher power generation.
- It is important to orient the active surface of the modules towards the south as much as possible in the northern hemisphere and towards the north as much as possible in the southern hemisphere.
- The metal support structure for the photovoltaic modules should be connected to ground in the manner indicated in the Low voltage Directive 93/68/EEC and 2006/95/EEC.
- Ensure that the cables of the installation that connect modules to other modules as well as those that lead to the load regulator batteries or any other part of the installations are not too tight since this could damage module Junction Box or the cables themselves. Use cable ties or cable clamps to fix the cables to the structure.
- Do not leave connectors unplugged for long periods of time; dirt may prevent subsequent connection. We recommend that the modules are connected in short-circuit to avoid this.
- Respect the electrical polarity of the modules. You must remember that they are direct current modules and as such direct current is required for their correct operation. In addition when connecting the different components of an isolated installation you must always connect the batteries first followed by the module and finally the power supply.
- Do not use the Junction box or the Junction box cables to hold or transport the module. You could damage some of its components and affect its waterproofness as well as the electrical security.
- Always handle the module with care even if it has the aluminum frame. Any blow on the glass or on a corner of the frame could deform it enough to break the glass.
- Do not dismantle modify or adapt the PV module. If you do so the guarantee will be invalid. Do not apply paint or adhesives to the back side of the PV module.



WARNING: PV POWER TECH shall not be held responsible or liable for any possible decrease in the electricity production of the photovoltaic module supplied, nor shall it consider said reduction to be a manufacturing defect if it is the result of the failure to observe the recommendations for use described herein.

Warnings and Electrical Hazards:

- The installations handling and maintenance of the photovoltaic modules must be carried out by qualified personnel duly equipped with individual protections.
- For information purposes these protections include: safety boots with insulation for above 1000 V gloves with 1000 V insulation as well as a helmet and appropriate clothes.
- Contact with AC (DC) voltage equal or higher than 30V is potentially dangerous. Do not use PV modules with different electrical or physical configurations in a single PV system. Keep children away from the system and the PV modules during installation. Do not carry out the installation in heavy rain or wind.
- For handling electrical components always use appropriate tools covered with insulating materials. It is recommended to avoid handling modules in humid conditions. Before handling and installing PV modules remove your rings and other metal jewels.
- It is important to remember that the active front panel of the module is made of glass and can break if it receives an impact. In cases of broken glass the module must not be installed as it will have lost the electrical insulation of the cells and will have a much lower performance level.
- Do not allow objects to fall onto the module.
- Do not sit lean or walk on the photovoltaic module.
- Do not open the connection box of the photovoltaic module. The cover of the connection box has a safety seal to guarantee to the customer that it has been correctly sealed to provide IP65 level of protection. If the cover is not correctly sealed there is a risk of damage to the module due to water ingress.
- Do not disconnect the terminals of the modules if they are electrically connected to other devices of the system. Before loosening connectors disconnect the modules from the inverter or the battery charger using switches. Before handling any electrical parts of the PV installations cover the active surface of the module from sun light.
- Do not use mirrors or magnifying lenses to concentrate light on the PV modules they are not designed for this.
- When handling and installing the module we recommend covering the active surface of the photovoltaic module since the modules generate electricity when they are exposed to any source of light even when they are not connected to any other device.
- Do not remove any of the module's components or remove the technical specifications label.
- Do not place the installation near to any possible source of inflammable gases or vapors since the photovoltaic modules can cause sparks just like any other electrical component.
- Always ensure the installation is equipped with protection devices against electrical hazards.
- Remember that when the modules are connected in series the voltage present will be the sum total of the voltage from each module and when the modules are connected in parallel

the current present will be the sum total of the current from each module. This means that an installation with various modules may contain high levels of voltage and current.

- When screwing the frame of the module to the structure avoid rubbing against the plastic insulation on the rear surface of the module (Backsheet) with the tool or elements protruding from the structure because this could cause the plastic to tear causing a loss of electrical insulation.
- The PV module produces power even with a broken glass or back sheet. Do not dispose of the module in containers or dumping sites this can be dangerous. If the glass or the back sheet is broken in case of electrical failure or if the service life of the module ends due to any cause in general please contact PV Power Tech to appropriately eliminate and/or recycle the product according to European norms.
- Consult the fire security regulations norms and prerequisites for buildings and structures with your local authorities. Keep in mind that a roof-top construction and installation may affect the building's fire security; erroneous installation of P modules can increase this risk in case of fire.



WARNING: Failure to comply with the provisions of this section will lead to the loss of guarantee and the exoneration of PV Power Tech from any type of responsibility for damage to property or injury to people.

Module Maintenance:

PV Power Tech photovoltaic modules require a minimum level of maintenance throughout their useful life which includes the following operations:

- Users should periodically clean the active surface of the modules with water or a non-abrasive detergent (avoid cleaning equipment that uses high pressure water). It is important that the active surface of the modules is kept clean in order to prevent any reduction of the power generated due to a layer of dust or bird excrement etc. In areas with medium to high levels of rain the rainwater is sufficient to keep the modules suitably clean throughout the year. In areas with low levels of rain the modules must be thoroughly cleaned at least once a year.
- Annual check of electrical connectors to ensure they are in good condition and correctly tightened. Visual inspection of the cables and cable glands. Annual or biannual review of the electrical characteristics of the modules to ensure that their performance level has not reduced.
- Annual or biannual review of the electrical characteristics of the modules to check that they are operating correctly.
- Visually inspect the active surface of the photovoltaic modules to verify that no hot-spots, delaminations, changes to the color of the cells, glass breakage etc. have occurred.



WARNING: Failure to perform the checks and minimum maintenance operations established in these instructions will lead to the withdrawal of all guarantees and the exoneration of PV POWER TECH for any responsibility which may be derived from said failure.

Current – voltage curves

The graphs of section 12 show the behavior of the photovoltaic modules
Two types of Current-voltage curves (I-V) are shown

At different radiations and constant temperature (25°C).

At different temperature and constant radiation (1000W/m²).

The standard test conditions or STC used for module labeling are:

Radiation = 1000 W/m²

Cell temperature = 25 °C

Air Mass = 1.5

It must be noted that the voltage and current behavior of the cells depends on the solar radiation and temperature. Therefore the actual operating conditions of a photovoltaic module will depend on the region where the module is installed and the ambient conditions in that region.

The voltage dependence in relation to radiation is defined by a logarithmic function: at low radiation levels a high voltage is obtained. However the current dependence in relation to radiation is defined by a linear function: it increases in direct proportion to the increase in solar radiation.

The voltage and current dependence with temperature is defined by a linear function. On one hand the voltage decreases as the temperature increases at a ratio of - 2.15 mV / °C per cell in series. On the others the current increases at +3.50 mA/°C. Therefore of the 7.5 to 8 amps that the module is capable of generating at 25°C, the current increases slightly with each degree centigrade of increase in the module temperature while the voltage decreases.

In general we observe a decrease of the photovoltaic module power as the operating temperature increases at a ratio of -0.43%/°C. For example a module of 220 Wp will lose 0.95 Wp for every additional °C in the cells.

The module operates at between 50 and 70°C when it generates electricity with radiation of between 800 and 1100 W/m² and a wind speed of less than 1 m/s.

Modules Groundings:

All exposed metal parts of PV module frames must be grounded during installation. The equipment grounding connection must be made using 10 AWG or larger conductors with insulation rated for at least 90°C.

The metal support structure for the photovoltaic modules should be connected to ground in the manner indicated in the Low Voltage Directive 93/68/EEC and 2006/95/EEC.

Declaration of CE conformity

We at PV Power Tech hereby declare under our sole responsibility that the Solar Photovoltaic Module product of the PV Power Tech brand models PVQ3 Series and the ECO Series Comply with the requirements of standards: EN 61000-6-1:2001, EN 60664-1:2003, EN 61000-6-3:2001, EN 60664-3:2003, EN 60270:2001, EN 60664-5:2003, EN 61140:2002, EN 61730-1:2007, EN 61730-2:2007 and are therefore in conformity with European Community Directives 2004/108/EC, 2006/95/EEC and 93/68/EEC

The product was labeled with the CE marking for the first time in 2009.